

## Highest Spectral and Spatial Resolution for Chemical Raman Imaging

**Raman microscopy is a high resolution imaging technique that has become widely used for the characterization of materials in terms of their chemical composition. Through the selection of optimized microscope components it is possible to approach the theoretical limit in spectral and spatial resolution. In this way information on sample properties can be obtained on the micro- and even nano-scale.**

### Confocal Raman Microscopes

Confocal Raman microscopy combines chemical sample characterization with the imaging capabilities of an optical microscope (Figure 1). Thereby a spatial resolution down to 200nm can be achieved. In a confocal microscope, only light from the focal plane is detected while out of focus light is rejected, thus providing depth resolution and a strongly reduced background signal (Figure 2). Images are recorded point by point and line by line while scanning the sample through the excitation focus. With this technique, the specimen can be analyzed in steps along the optical axis and even depth profiles or 3D images can be generated.

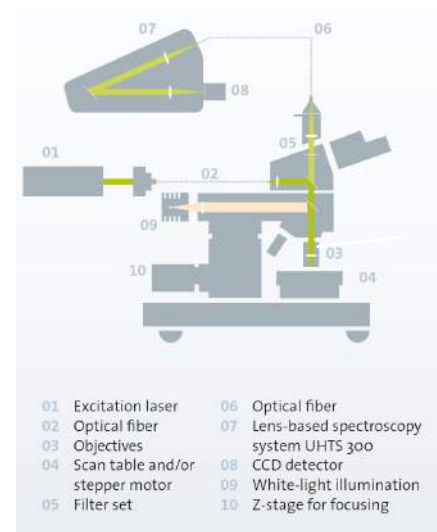

**Figure 1:** Beam path of a confocal Raman microscope

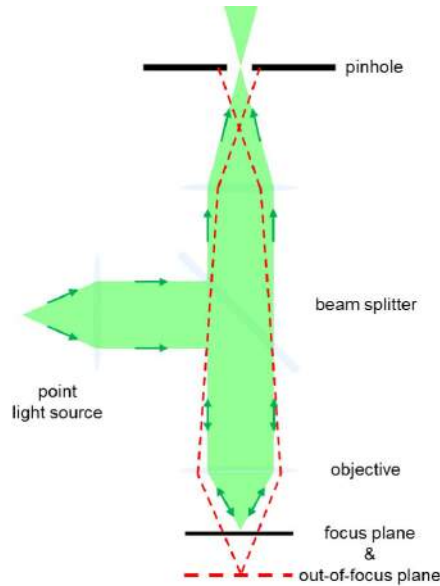

**Figure 2:** The basics of a confocal microscope: Only light from the focal plane is detected, while out of focus light is rejected.

### The Resolution

The spectral and spatial microscope resolutions are important factors for the quality of the acquired measurements. The spectral resolution of a confocal Raman microscope is mainly defined by the individual components of the spectroscopic system. The focal lengths, the grating, the pinhole, the pixel size of the CCD camera, and the imaging quality of the spectrometer all contribute to optimization.

In case of the spatial resolution of a confocal Raman microscope the lateral (x- and y-direction) and the depth resolution (z-direction) can be distinguished. Besides the fundamental laws of physics (e.g. the diffraction limit), the spatial resolution is defined by the mechanical and optical microscope components which can influence the sample position accuracy, aberration, and beam path distortion.

In Figure 3 the experimental determination of the lateral resolution of a confocal Raman microscope is shown. The measurable lateral dimensions of a carbon nanotube sample can be determined via the FWHM (full width at half maximum) and the lateral resolution can be characterized at about 272nm. Furthermore the depth resolution is an important characteristic of a confocal system. The instrument design and also the pinhole and the sample illumination influence the depth resolution. With the usage of proper microscope components a depth resolution below 750nm can be achieved.

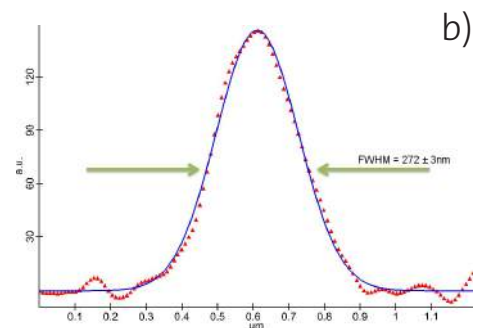
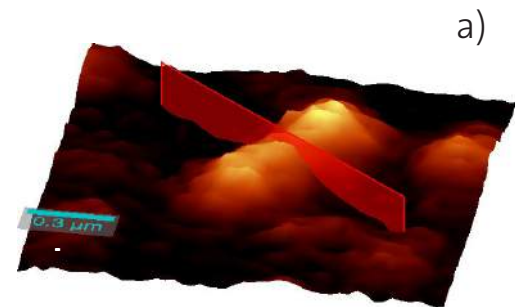

**Figure 3:** a) Integrated intensity of the G-Band of a carbon nanotube with the cross section position marked in red and the cross-sectional intensity along this line in (b). The lateral resolution of the microscope system can be characterized by the FWHM and is about 272nm.

## High-resolution and large-area 3D image acquisition

Figure 4 shows a large-area, high-resolution image of the lotion, where the API is dissolved in water. The large image is the result of an evaluation of 4.194.304 complete Raman spectra (raw data file: 12.5 Gbyte). Consecutive zooms in the same dataset are presented in Figure 4b and 4c. In all three images the water and API containing phase is presented in blue color, whereas with green color the oil-matrix is presented. Beside the distribution of the known materials, silicone based impurities could be visualized (red color in the images). The detection of such small impurities requires such high resolution large area Raman images. The volume of the impurities can be determined from a stack of confocal Raman images as presented in Figure 5. For these measurements a volume of  $25 \times 25 \times 20 \mu\text{m}^3$  was measured, using  $200 \times 200 \times 50$  pixels (total of 2 million spectra, data file 6 Gbyte).

## Conclusion

The spectral and spatial resolution of a confocal Raman microscope setup can be optimized by the usage of ideal optical and mechanical microscope components. In this way high-resolution depth scans and 3D Raman images can be generated and information about the chemical sample composition can be obtained.

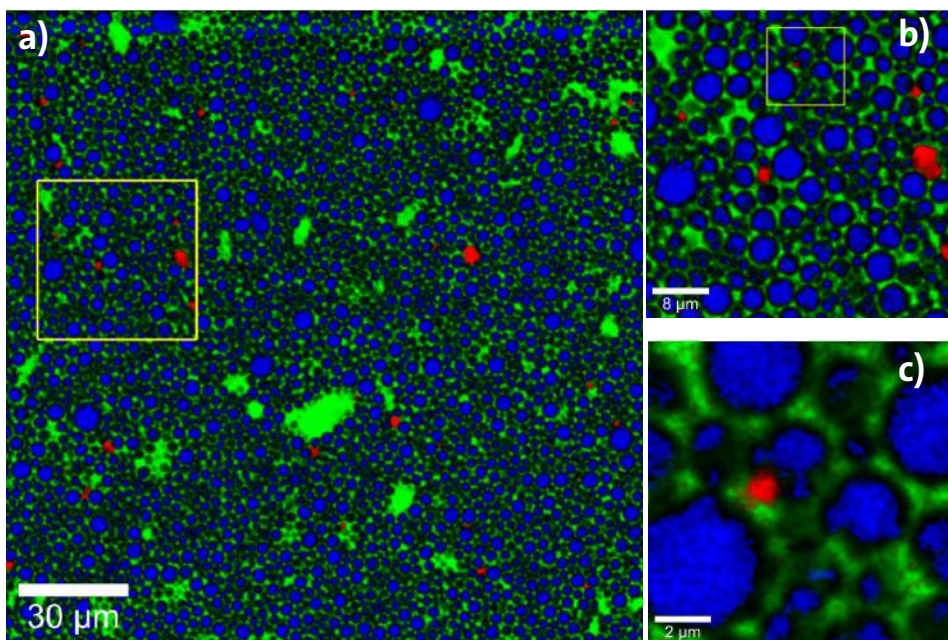

**Figure 4:** a): High-resolution, large-area Raman image of a lotion. Image parameter:  $175 \times 175 \mu\text{m}^2$ , 2048x2048 complete Raman spectra, integration time per spectrum: 0.002 s (total acquisition time of 2h30min). b) and c): The zoom-ins demonstrate the high-resolution of the Raman image.

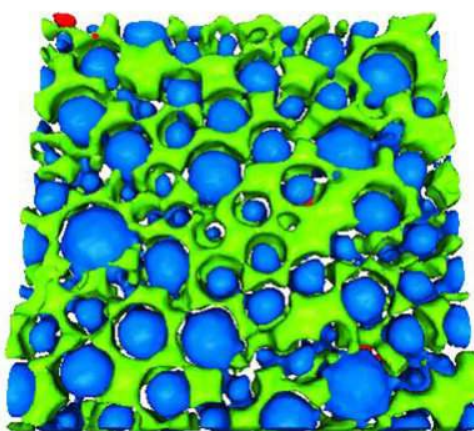

**Figure 5:** 3D confocal Raman image acquired from the lotion. Sample volume:  $25 \times 25 \times 20 \mu\text{m}^3$ ; image stack:  $200 \times 200 \times 50$  pixels (total of 2 million spectra, data file 6 Gbyte).

## Advantages and Benefits for your

### Applications:

- outstanding imaging capabilities with an exceptional performance in speed, sensitivity and resolution
- highly confocal imaging system with an excellent depth-resolution for 3D imaging and depth profiles

- fiber based light transmission with up to 90% throughput of laser light
- ultra-fast Raman imaging with acquisition times of only 0.76 ms per spectrum
- combinations of Raman with AFM, SNOM, profilometry and many other imaging techniques within one instrument



alpha500 Raman AFM microscope